

# PermEntry®

*The Complete Basement Entrance*



Imagine...  
What Bilco can do for your basements

# Plan for it on New Homes

The PermEntry Basement Entrance adds sales appeal and value by giving homeowners access directly from the basement to the outdoors. When you plan for a PermEntry Basement Entrance, you open up your basement to a number of opportunities, including:

- External basement exit in case of an emergency.
- Access to mechanical equipment during construction, reducing traffic and damage to the main level of the home.
- Ability to move large furniture, bulky appliances and patio furniture easily through the basement.
- Additional quality selling features your customers will recognize and appreciate.
- A basement as convenient and easy to use as other rooms in the home.

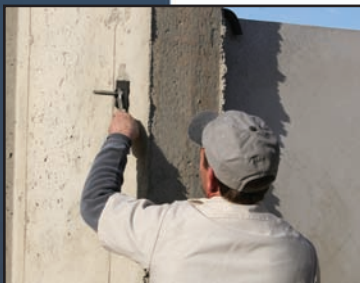

## You supply the foundation opening... PermEntry does the rest!

- Holes for the special high-strength bolts are drilled through foundation.
- Facing surfaces are coated with self-sealing butyl resin strip sealant for a watertight seal. The PermEntry precast stairwell is then lowered into position onto the foundation footing.
- Precast stairwell is secured prior to backfill through foundation wall using built-in steel anchors. On a block or precast foundation, a permanent steel support is installed on a concrete slab underneath the precast unit.
- The Bilco door is anchored to the precast stairwell and caulked. The area is then backfilled and landscaped. For steel doors, a finish coat of acrylic latex in white or light color must be applied to all interior and exterior steel surfaces within forty-five (45) days of installation. Note: Bilco does not recommend the use of Rust Oleum products.

The complete installation of the precast stairwell and door is typically done in under two hours.

Model Home Program is available.  
See [www.bilco.com](http://www.bilco.com) for more information

## Ultra Basement

PermEntry is also available as an Ultra Basement door. The Ultra is a modern alternative to the traditional basement door.



### Features:

- High-density polyethylene resists rusts, rots or needs painting
- Attractive wood design
- Motion dampers provide smooth door operation
- Sturdy inside locking mechanism
- Interchangeable side panels for ventilation



**Whether you specify PermEntry for your new home or add it to your existing home, you'll enjoy these benefits...**

- Convenient direct basement access
- Building code compliance for emergency egress (IRC 2009)
- Professional installation by a certified dealer
- Added sales appeal for your home

## Add it to Existing Homes

### Series t Door

e with the Ultra Series  
is a maintenance-free  
al steel basement door.



construction never  
g

for safe and controlled

anism

l inserts for light

Homeowners can add the convenience of direct basement access by following these simple steps...

- Contact a PermEntry dealer to determine if your home is suitable for a PermEntry installation.
- Stake off the area to be excavated. Call your local utility companies to verify power and utility line locations.
- Hire an excavating or landscaping contractor to dig the opening for the precast stairwell (see back panel for opening requirements)
- Contact a contractor to saw cut an opening in your foundation wall. Your PermEntry dealer can help you find a contractor.
- Ask your PermEntry dealer for help on determining the proper size of your areaway and to set up delivery and installation.
- Once the entrance has been installed, back-fill and landscape the area around your new basement entrance. The basement door is supplied with instructions for painting and maintenance.



**Pre-Installation Requirements:**

1. Provide truck access to within 10' of the center of the PermEntry unit.
2. Foundation footing and opening should be LEVEL, PLUMB and SQUARE.
3. Width of opening in foundation wall should be 40" maximum for all sizes.
4. Ensure proper soil drainage at base of unit. A footing drain to daylight is recommended.
5. When foundation is backfilled, leave minimum work area for PermEntry installation as shown.
6. Basement floor or equivalent slab should be poured in the concrete wall.
7. Hold foundation tar coating back minimum 12" each side of opening.

**How to Measure:**

1. Determine the measurement from the finished grade to the foundation footing.
2. Refer to table below to select proper size. Top of casting should be a minimum of 2" above finished grade.
3. Double check your pre-installation requirements and check site to determine that there is proper truck access to and from the PermEntry installation site.

**Post-Installation Requirements:**

1. Properly backfill and compact excavation with clean, suitable fill and/or stone. NEVER USE CONSTRUCTION DEBRIS and NEVER backfill higher than 2" below top of concrete casting.
2. Final grade should be adjusted to leave 2"-6" of casting above finished grade, immediately slope grade away from the PermEntry unit in all directions.
3. Avoid locating down spouts or sump discharge near the PermEntry unit.
4. An insulated door at bottom of stairs is recommended to reduce heat loss.
5. A finish coat of acrylic latex in white or light color must be applied to all interior and exterior steel surfaces within forty-five (45) days of installation. Note: Bilco does not recommend the use of Rust Oleum products.

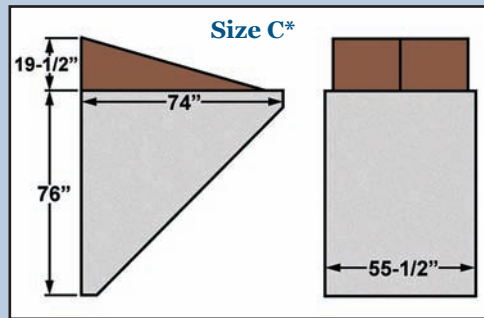
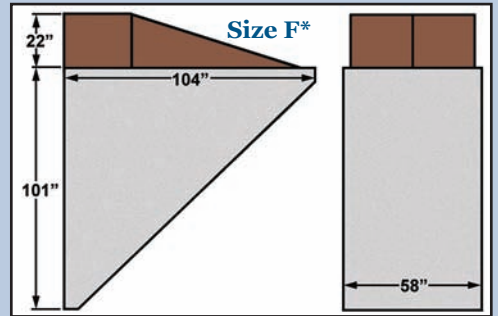
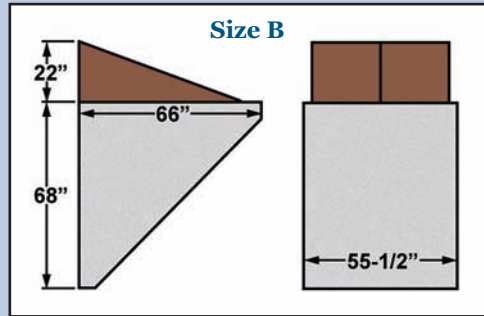
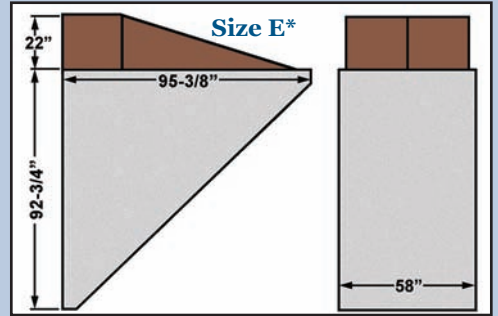
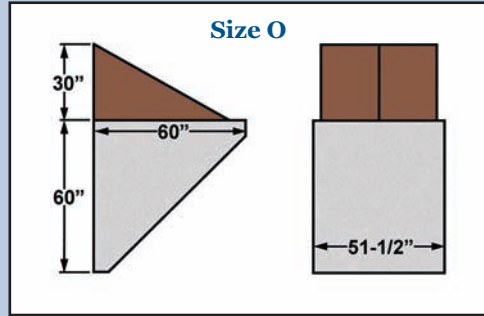
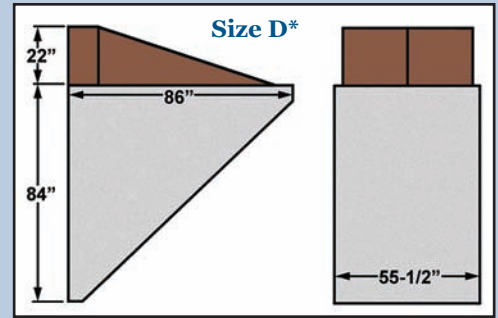
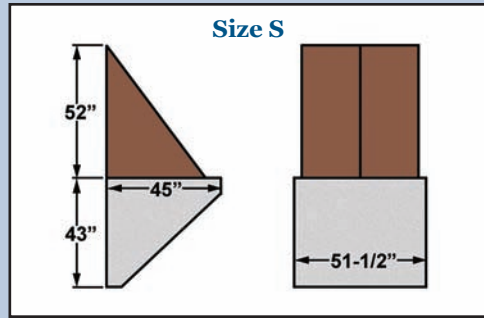

PermEntry Size	Footing to Grade
S	35" - 41"
O	52" - 58"
B	59" - 66"
C*	67" - 74"
D*	75" - 82"
E*	83" - 91"
F*	92" - 99"

**Job Requirements**

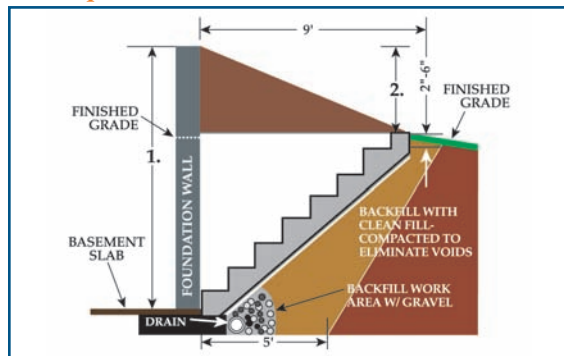

**How to Order**

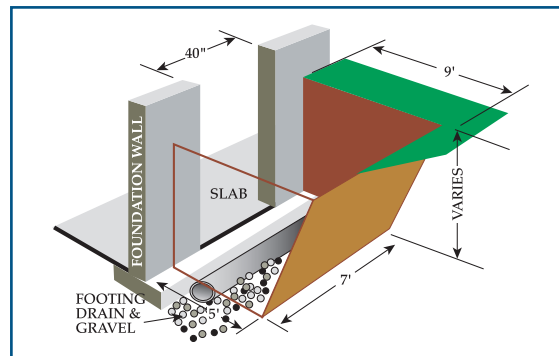

\* Optional Ultra Series Door available for sizes C, D, E and F only.



An optional basement door keyed lock kit is available for added home security.



Imagine...  
What Bilco can do for your basements  
(800) 854-9724 • www.bilco.com

**Licensed Dealer**